

**Oconnor  
1040  
Fluid Pan & Tilt Head**



Part No. C1265-0001

**Copyright © 2019**

All rights reserved.

Original Instructions: English

All rights reserved throughout the world. No part of this document may be stored in a retrieval system, transmitted, copied or reproduced in any way, including, but not limited to, photocopy, photograph, magnetic or other record without the prior agreement and permission in writing of the Videndum Group Plc.

**Disclaimer**

The information contained in this manual is believed to be correct at the time of printing. Videndum Production Solutions reserves the right to make changes to the information or specifications without obligation to notify any person of such revision or changes. Changes will be incorporated in new versions of the publication.

We are making every effort to ensure that our manuals are updated on a regular basis to reflect changes to product specifications and features.

Should this manual not contain information on the core functionality of your product, please let us know. You may be able to access the latest revision of this manual from our website.

Videndum Production Solutions reserves the right to make changes to product design and functionality without notification.

**Trademarks**

OConnor® is a registered trademark of the Videndum Group Plc.

All product trademarks and registered trademarks are the property of The Videndum Group Plc.

All other trademarks and registered trademarks are the property of their respective companies.

**Published by:**

Videndum Production Solutions

Supports Technical Publications Department

Email: [technical.publications@videndum.com](mailto:technical.publications@videndum.com)

<b>Safety / About This Guide</b> .....	<b>3</b>	<b>Operation</b> .....	<b>17</b>
Health and Safety .....	3	Operating the Pan and Tilt Locks .....	17
Mounting and Installation .....	3	Pan and Tilt Fluid Drag .....	18
About this guide .....	4	<b>Maintenance.</b> .....	<b>19</b>
<b>Box Contents</b> .....	<b>5</b>	Battery Replacement .....	19
<b>Optional Accessories.</b> .....	<b>6</b>	Adjust Lock Levers. ....	20
<b>Components.</b> .....	<b>7</b>	Adjust Camera Plate .....	21
Front View .....	7	<b>Technical Specifications</b> .....	<b>22</b>
Rear View .....	8		
<b>Installation.</b> .....	<b>9</b>		
Mounting the head .....	9		
Levelling the Head .....	9		
Remove / Install Camera Plate Platform. ....	10		
Fitting the Pan Handle .....	12		
Mounting the camera .....	13		
Payload Weight and C of G Height Adjustment ...	13		
Balancing the Payload .....	15		

# Safety / About This Guide

Important information on the safe installation and operation of this product. Read this information before operating the product. For your personal safety, read these instructions. Do not operate the product if you do not understand how to use it safely. Save these instructions for future reference.

## Warning Symbols Used in These Instructions

Safety cautions are included in these instructions. These safety instructions must be followed to avoid possible personal injury and avoid possible damage to the product



**WARNING!** Where there is a risk of personal injury or injury to others, comments appear supported by the warning triangle symbol. Where there is a risk of damage to the product, associated equipment, process or surroundings, comments appear supported by the word '**CAUTION**'.

## Health and Safety



**WARNING! Risk of personal injury or injury to others.** All personnel must be fully trained and adhere to correct manual handling techniques and Health & Safety regulations. It is the responsibility of the local organisation to enforce safe working practices at all times.

## Mounting and Installation



**WARNING!** Risk of finger entrapment. Do not place fingers between the platform and body of the fluid head.



**WARNING!** Avoid trapping fingers when collapsing and extending tripod legs.



**WARNING! Risk of finger entrapment.** DO NOT fit the head to a tripod that cannot support the combined mass of the head and its full payload.



**WARNING! Toppling hazard.** Do not leave unattended. Keep out of reach of children.



**WARNING!** The product must always be secured.



**CAUTION!** Always lock the vertical and horizontal brakes when the camera is mounted but not in use or when levelling the fluid head on the tripod.



**CAUTION!** Hold the camera securely when mounting or dismounting from the fluid head and when making adjustments to the tripod height or footprint.



**CAUTION!** Always hold the pan bar when making adjustments to the counterbalance or camera position. Do not use the pan bar to lift or move the tripod and fluid head.



**CAUTION!** Only attach camera accessories to the pan bar. Do not attach heavy items to the pan bar.



**CAUTION!** Always remove the camera before transporting.



**WARNING!** Before fitting or adjusting the camera or payload the tilt lock must be engaged.

## Maintenance



**WARNING!** The fitting of non-approved parts and or accessories, the carrying out of non-approved alterations or servicing can be dangerous and could affect the safety of the product. It may also invalidate the terms and conditions of the product warranty.



**Caution!** When replacing the battery, use only the same or an equivalent type of battery recommended for use with the product.

## About this User Guide

### OConnor Ultimate 1040 Fluid Head

This guide describes the installation, configuration and operation of the OConnor Ultimate 1040 Fluid Head.

The Ultimate 1040 fluid head brings the same quality build and precision movement found the larger OConnor 2575 and 2065 heads to enable cinematographers easily move from heavier to lighter payload camera set-ups without compromise.

Features of the lightweight yet sturdy fluid head include a step-less, ultra-smooth pan and tilt fluid drag custom designed to provide ultimate control and stability, as well as the OConnor Sinusoidal Counterbalance system that provides true, accurate balance at any point in the tilt range. Providing perfect balance even for lighter-weight cameras with counterbalancing down to zero, the Ultimate 1040 head is made with high-performance magnesium, and aluminium alloys with stainless steel and genuine carbon fibre finishing, to deliver consistent results on the most demanding sets.

For camera operators, making the change to smaller, lighter cameras while retaining quality has never been easier. And most importantly, the famous OConnor feel, remains the same regardless of payload.

The versatile OConnor Ultimate 1040 supports payloads from 0 to 45 lbs. (20 kg) at a 5" (15 cm) centre of gravity and a +/-90° tilt range.

# Box Contents

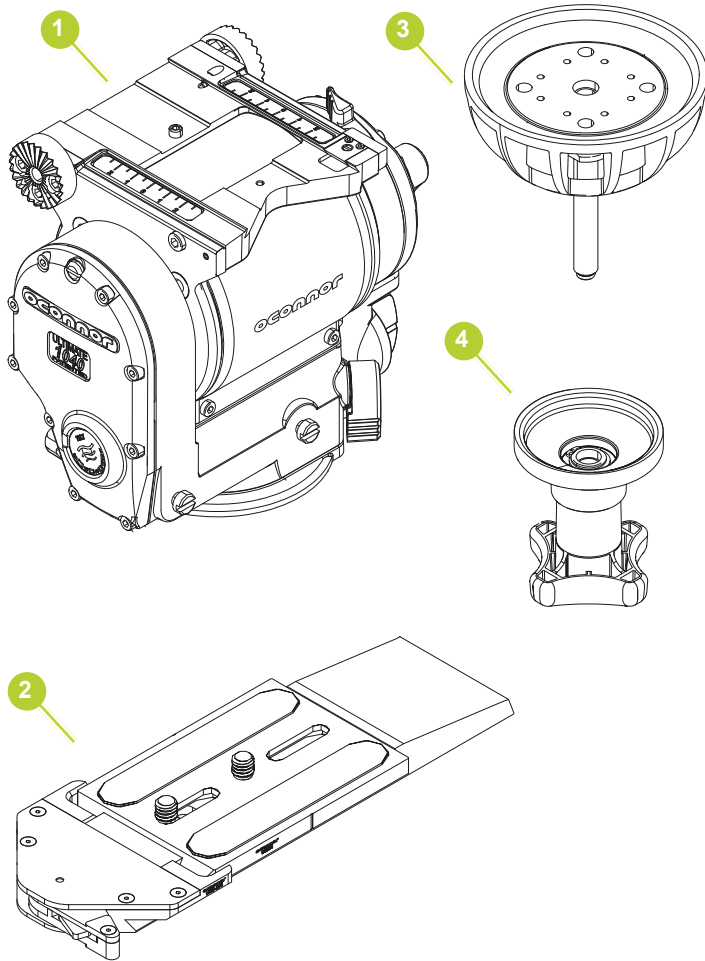

1	1040 Head	C1265-0001
2	Large Euro Quick Release + Plate	1030-268
3	100 mm Ball Base	08365
4	100 mm Tie down	S2052-1100
5	Pan handle	1030-246
6	Pan handle extension	2575-135

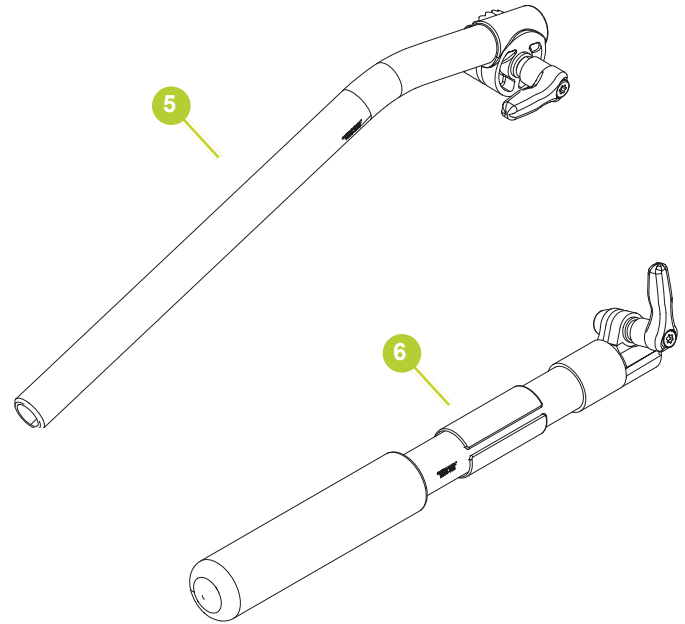

# Optional Accessories

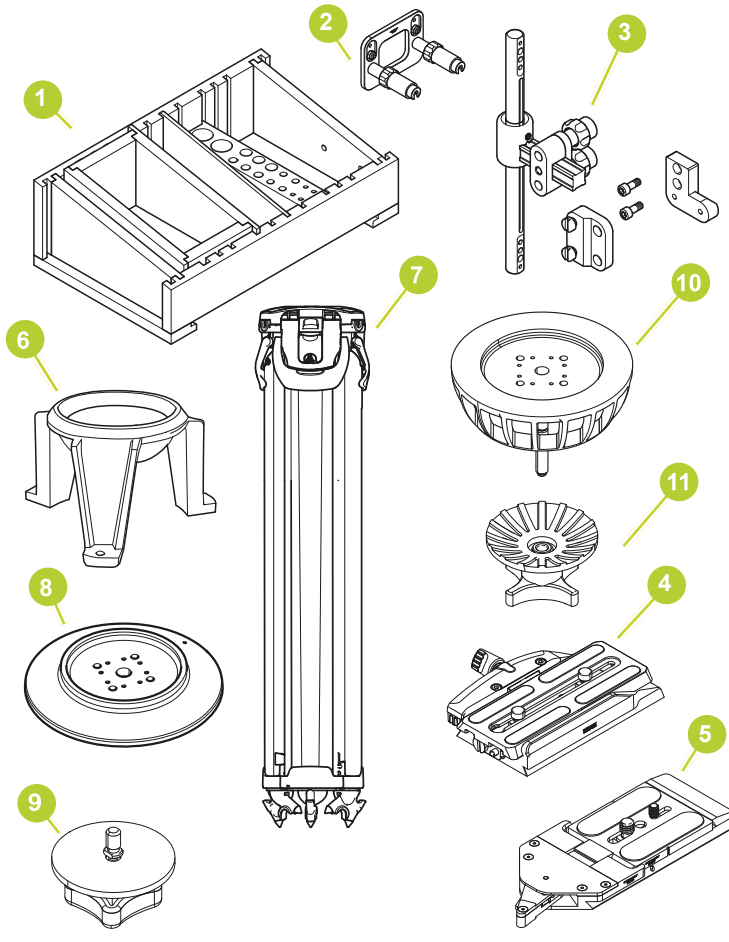

1	Assistants box	CSE-MFB100
2	Front box mount	08308
3	Eye piece leveller	C1504-1000

## Platform Assemblies & Plates

4	Large Euro quick release (includes large Euro Plate Part No. <b>08285</b> )	C1030-268
5	Camera Slide Plate assy. (Includes Mini Euro Plate Part No. <b>08427</b> )	V4045-1901

## Tripods + Hi Hats

6	100mm Hi Hat	45A-0002
	30L Tripod ( <b>Not Shown</b> )	C1251-0001
7	flowtech 100mm tripod	C1266-0002

## Bases

8	Mitchell Base assy. 100mm	08281
9	Mitchell Tiedown	C1234-1018
10	150mm Ball Base	08414
11	150mm Ball Tiedown	C1234-1017
12	Studio Pedestal / Tripod Adaptor	08349

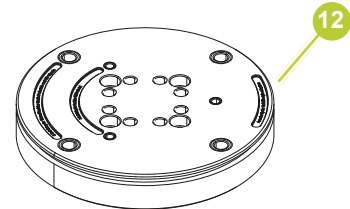

# Components

## Front View

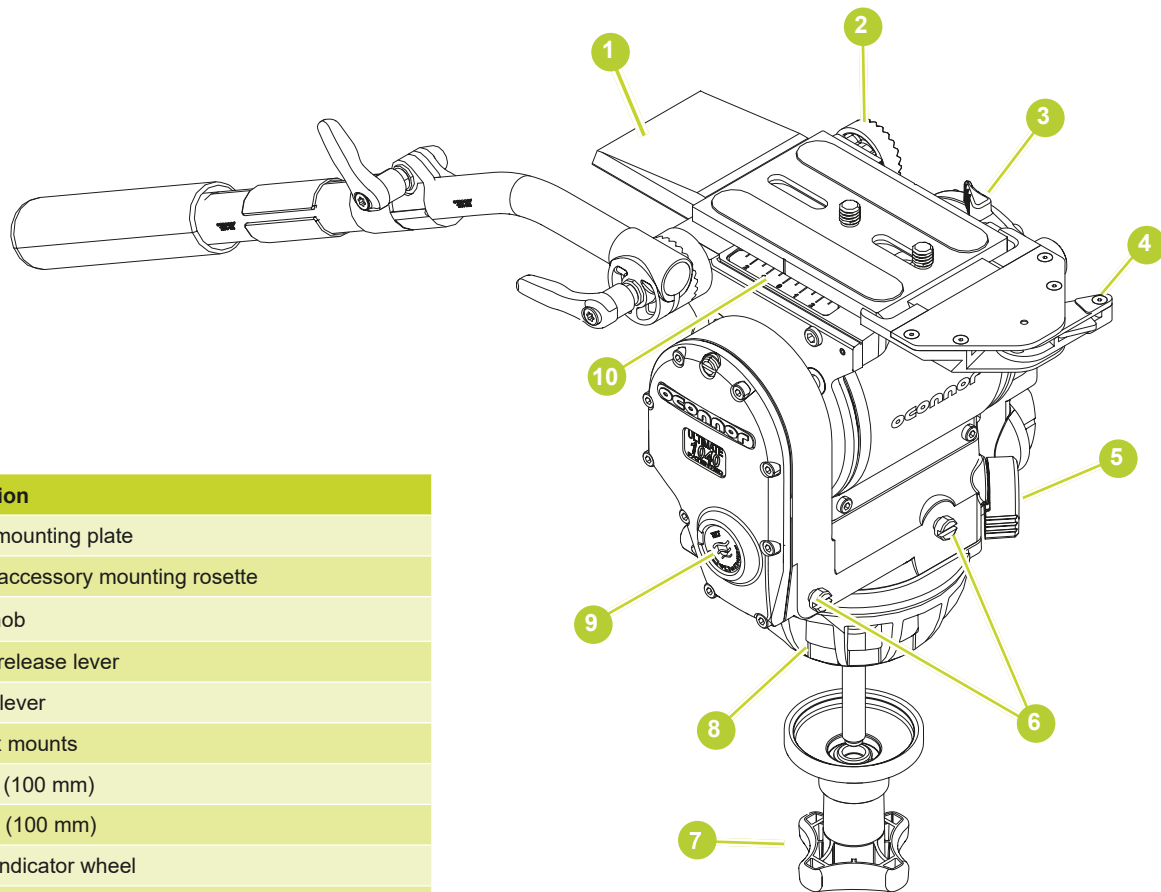

Position	Description
1	Camera mounting plate
2	Handle / accessory mounting rosette
3	Clamp knob
4	Platform release lever
5	Pan lock lever
6	Front box mounts
7	Tie down (100 mm)
8	Ball base (100 mm)
9	Tilt drag indicator wheel
10	Platform scale



## Rear View

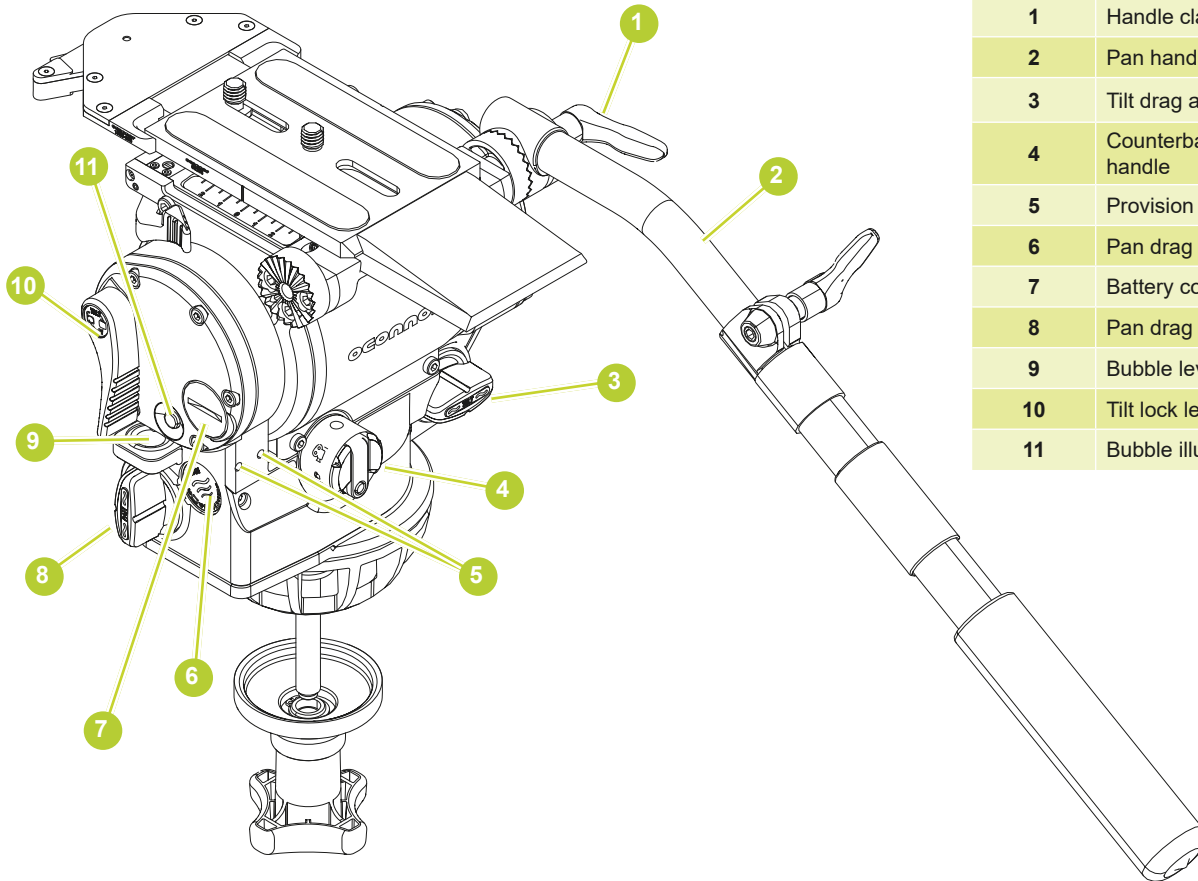

Position	Description
1	Handle clamp
2	Pan handle
3	Tilt drag adjustment knob
4	Counterbalance crank handle
5	Provision for attachments
6	Pan drag indicator wheel
7	Battery compartment
8	Pan drag adjustment knob
9	Bubble level
10	Tilt lock lever
11	Bubble illumination button

# Installation

## Mounting the Head

The 1040 is installed onto standard tripods using the 100mm ball base and tie down  
Other bases are available (See optional accessories).



**WARNING!** Toppling hazard. Do Not fit a head to a tripod that cannot support the combined mass of the head and its full payload.



**WARNING!** If required use a mid-level or floor spreader to ensure that the tripod legs are spread sufficiently; this ensures that the C of G remains within the footprint of the tripod.



Refer to the tripod instructions supplied with the tripod for correct fitting procedure.

## Leveling the Head

After securely mounting the head on to the tripod, center the bubble level to set the level.

If necessary, in poor light conditions:

1. Press the button illumination bubble (the light will remain on for 20 seconds).

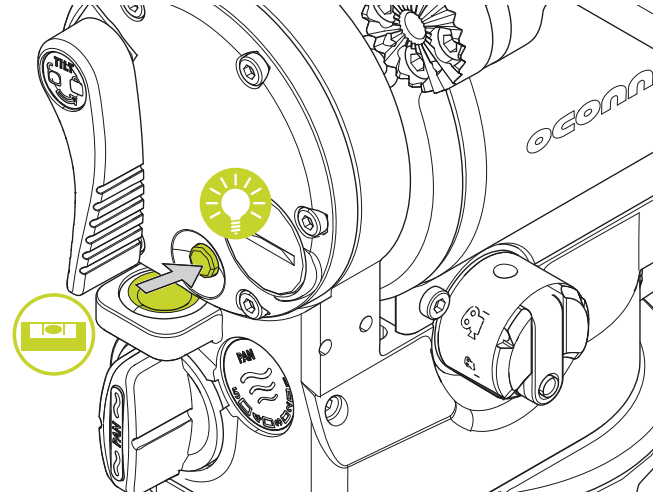

## Ball Base

Loosen the bowl clamp. Move the fluid head to center the level bubble.

Tighten the bowl clamp and re-check the level.

## Remove / Install Camera Plate Platform

The camera plate can be installed facing front or rear depending on the required load and balance requirements.

1. Remove the camera plate as described on "Mounting the camera" on page 13.
2. Release the plate slide lock (A) by levering in a clockwise direction.
3. Before sliding the plate away from the head, remove the Hex stop screw (B).
4. Slide the platform forwards to remove from the head.

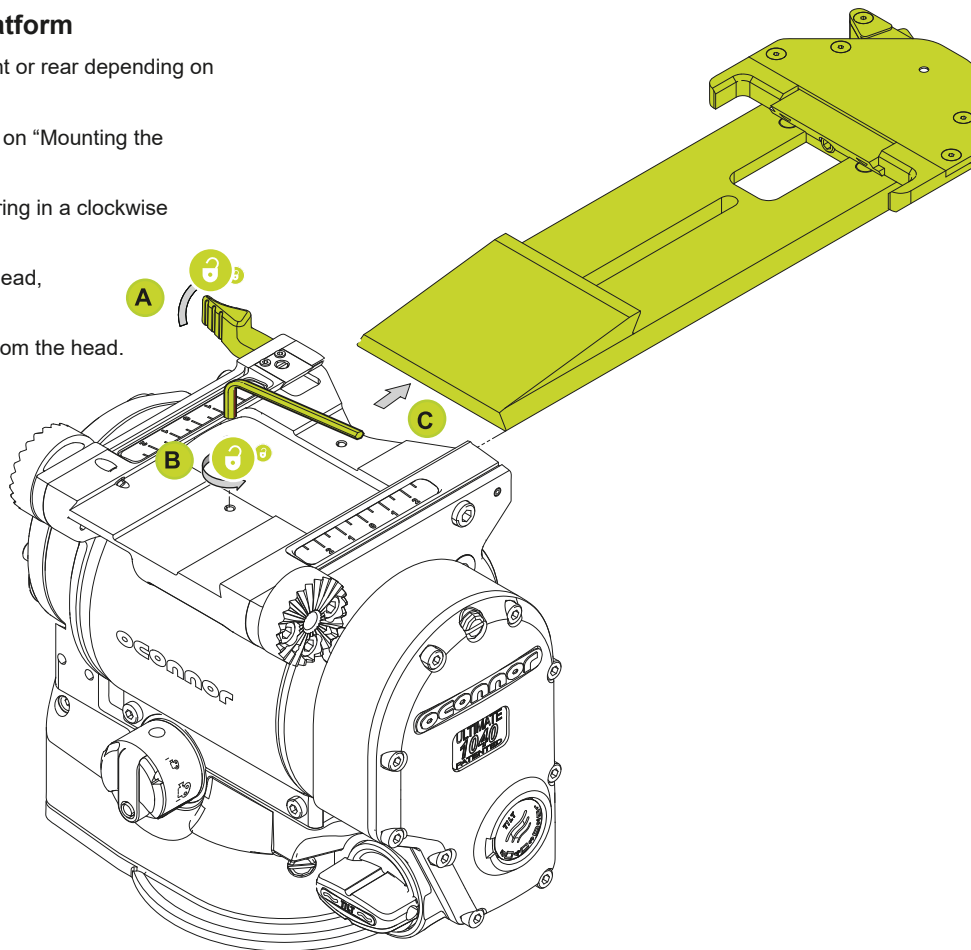

# Installation

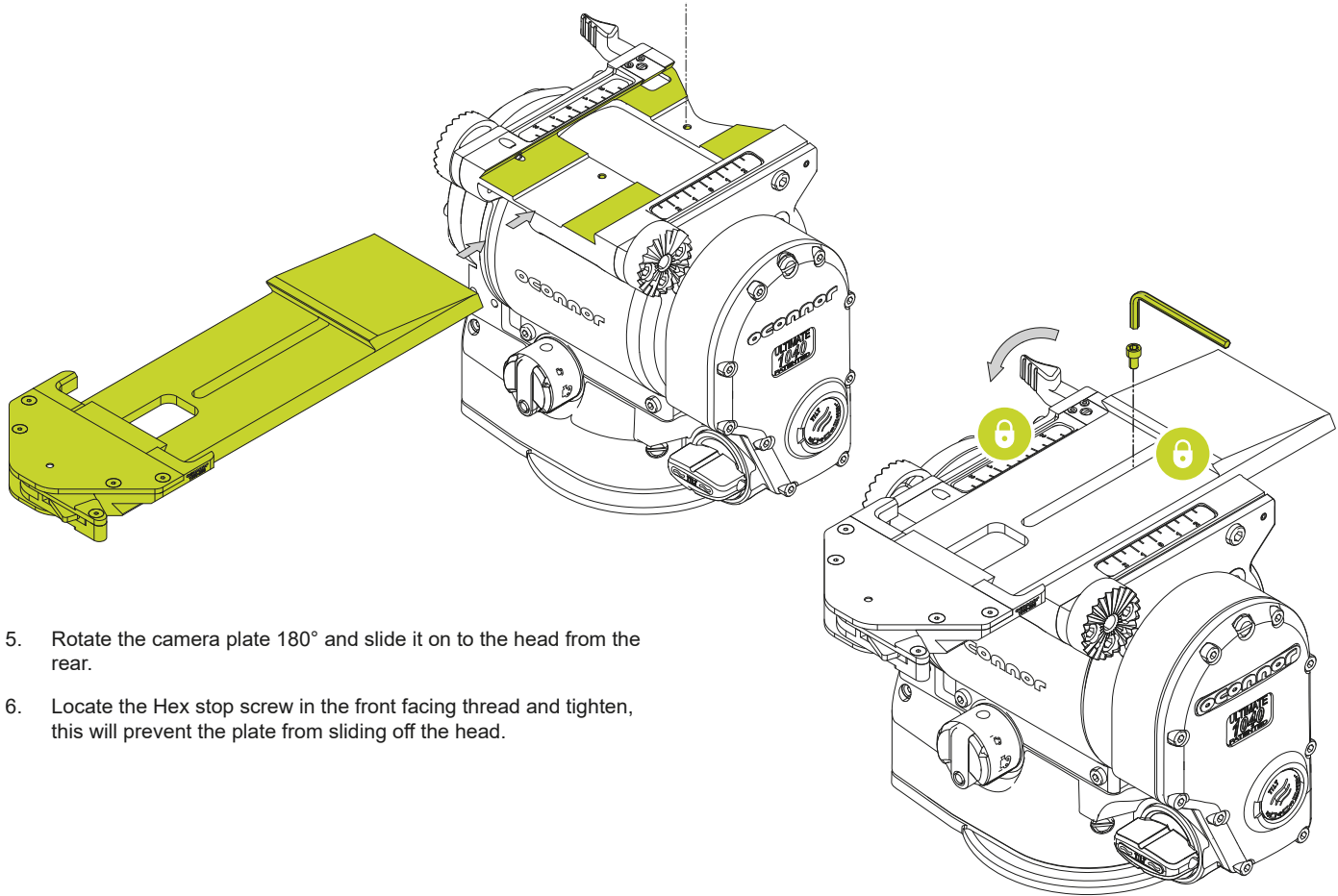

5. Rotate the camera plate 180° and slide it on to the head from the rear.
6. Locate the Hex stop screw in the front facing thread and tighten, this will prevent the plate from sliding off the head.

## Fitting the Pan Handle

Pan Handle accessory mounting rosettes are located at the rear of the head, on both left and right sides.

The pan handle may be positioned on the rosettes in any position to suit the user requirements.

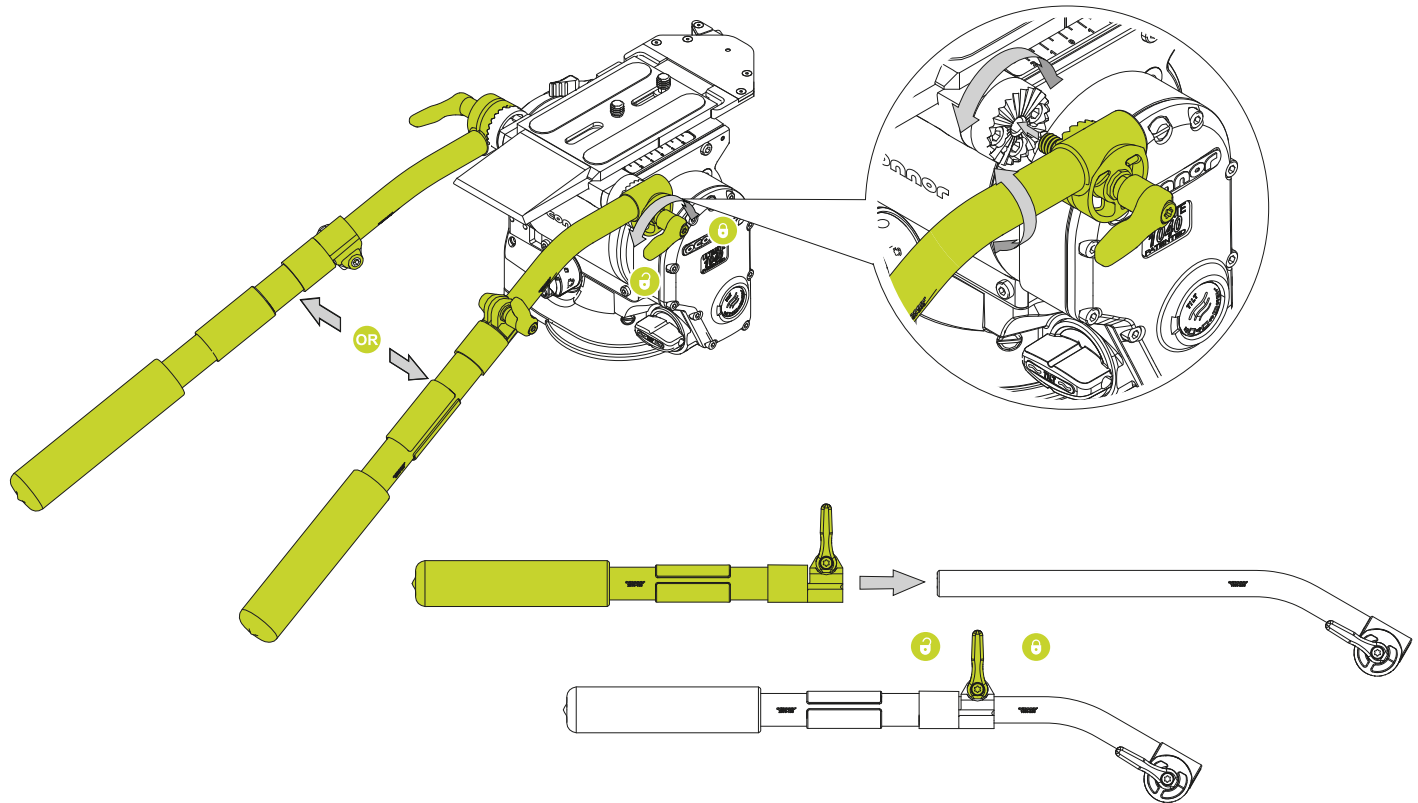

# Installation

## Mounting the Camera



**WARNING!** Ensure that the weight and C of G height of the total payload is within the range for which the head is designed.

## Payload Weight and C of G Height Adjustment



**WARNING!** For safe and reliable operation the head and all mounted equipment must be correctly balanced.

The chart below shows the range of load and C of G heights that can be maintained in balance. The area below the balance curve (to the left) corresponds to load / C of G combinations that can be balanced over the full tilt range of the 1040. The area above the balance curve (to the right) corresponds to load / C of G combinations that exceed the capacity of the head.

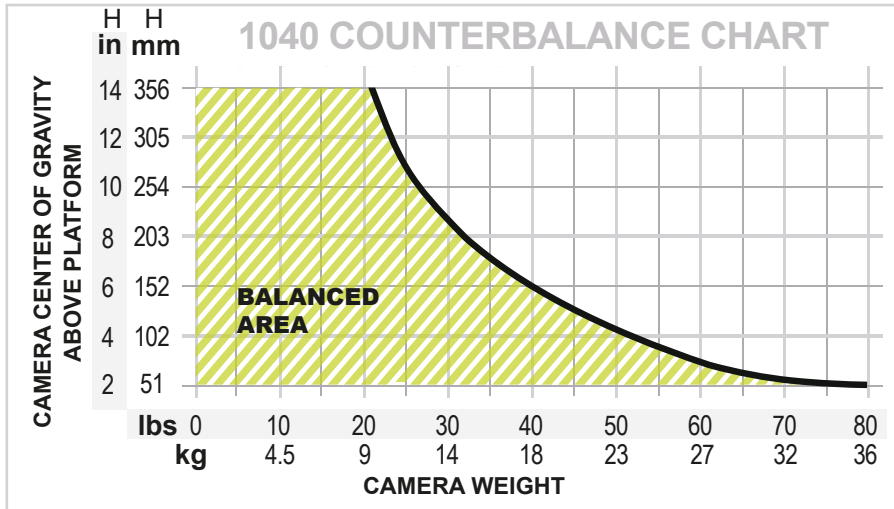

**Tip.** The height of the C of G is difficult to measure, especially with accessories fitted. Accessories fitted high above the camera will effectively reduce the total payload that can be balanced.

However, since accessories are fitted both above and below the lens, a first approximation can be the distance from the bottom of the camera plate to the centre of the lens.

Approximate estimate for C o G Height (dependant on configuration).

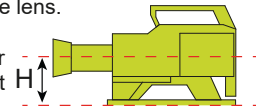

- @ 4" (100mm) <52 lb. (23.5 kg)
- @ 5" (127mm) <45 lb. (20.4 kg)
- @ 6" (152mm) <40 lb. (18.1 kg)
- @ 8" (203mm) <33 lb. (14.9 kg)

If you are installing the head on a crane, pedestal, or dolly, you must lock them before installing the camera.

## To Mount the Camera:

1. Level the head and engage the tilt lock.
2. Remove the camera mounting plate from the platform. Push the release (A) button at the front of the platform towards the front of the head, rotate the lock lever (B) clockwise 180° (C) and lift out the camera plate.

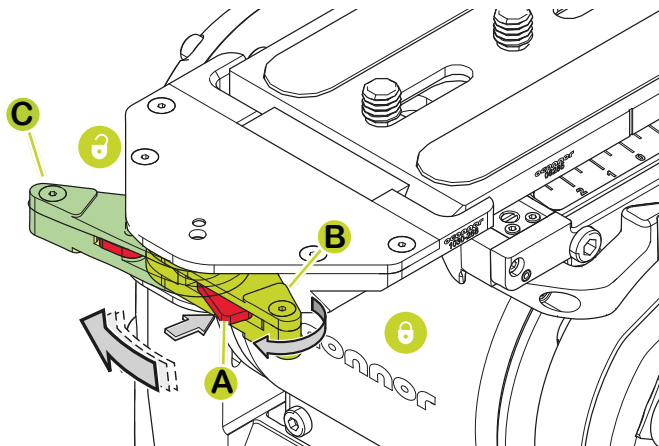

3. Securely attach the camera plate to the bottom of the camera (D).
4. Insert the camera plate into the platform. Push it into the dovetail at the rear of the platform, with the clamp in position (E), then push the front down until the platform hook engages with an audible 'click' (F). Note that the camera is now captive, but not locked.
5. To lock the camera mounting plate, turn the clamp lever on the platform fully counter-clockwise (G). The clamping mechanism will engage with the camera plate securing the camera in position. Ensure the camera plate is firmly locked and there is no movement of the camera relative to the head platform. If there is movement see **“Adjust Camera Plate” page 21** for plate adjustment.
6. Install the remainder of the payload (lens, zoom and focus controls, viewfinder, etc.) before unlocking the tilt lock.

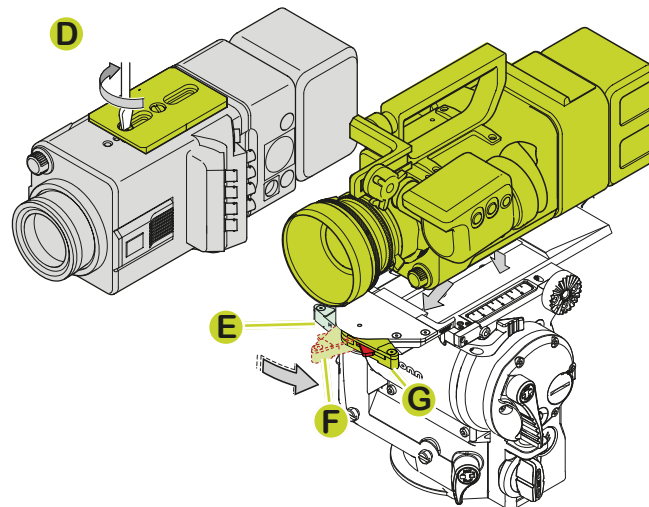

# Installation

## Balancing the Payload

The purpose of setting the balance and counterbalance of the payload is to negate the weight of the payload when tilting the head. The movement should be effortless and the payload should remain in any set position throughout the tilt range.

Ensure the head is level before balancing. The camera and payload should be fitted on the head, so that the load is balanced. This can be achieved by moving the camera forwards (Fore) or backwards (Aft) on the cradle.



**WARNING!** When positioning the payload, it is important to be aware of the potential danger that an unbalanced payload will fall away suddenly. Always be prepared for this by maintaining a firm hold of the handle, until the balance is set correctly.



**WARNING!** The payload balancing procedure may require the assistance of another person.



**Caution!** The camera, handles and all accessories must be fitted in their operational position before balancing the head. Any equipment fitted or adjusted later can unbalance the head.

1. Make sure the tilt lock is engaged and that the camera and all accessories are installed in their operating positions.
2. Set the tilt drag adjustment knob to '1' (lowest setting).
3. Initially, set the counterbalance quite high; turn clockwise .



Depending on the payload weight, it may be necessary to increase or decrease this setting to enable the payload to be correctly balanced fore and aft.

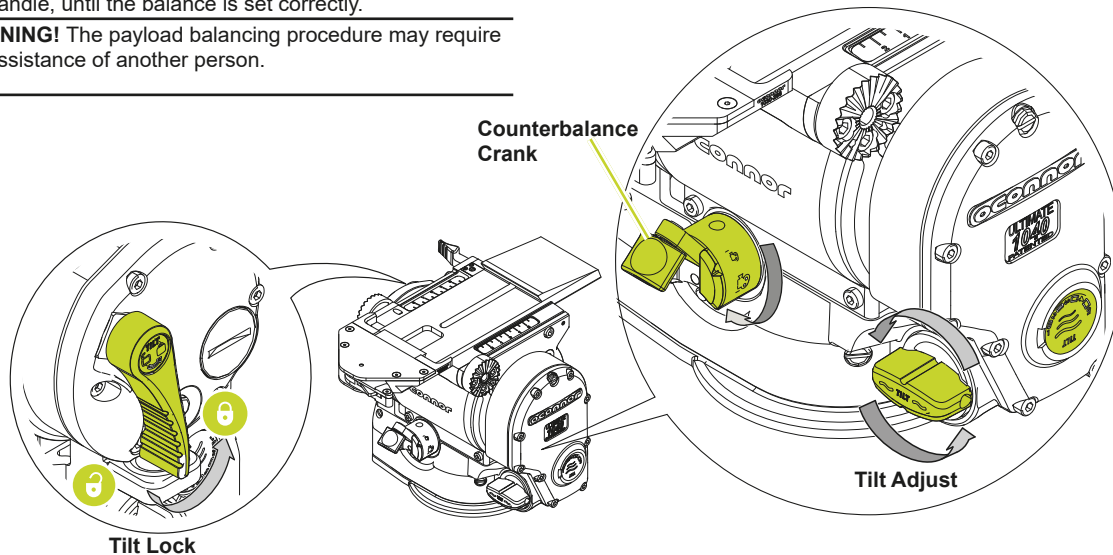



- The payload C of G (Centre of Gravity) must align with the fluid head's tilt axis as shown below, slide the payload fore and aft using the camera plates sliding platform until the load is centered and balances upright in the vertical position with the tilt lock and drag off. Lock the tilt when done.



It is unlikely that perfect balance will be achieved at this point without supporting the load. You are looking for the balancing point between the load falling fore or aft

If this cannot be achieved then reposition the camera plate.

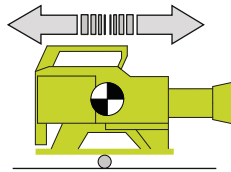

**Tip.** Before initially mounting the camera. If the camera C of G is unknown, it may be estimated by placing the camera on a rod and shifting it fore and aft until the balance point (C of G) is achieved.

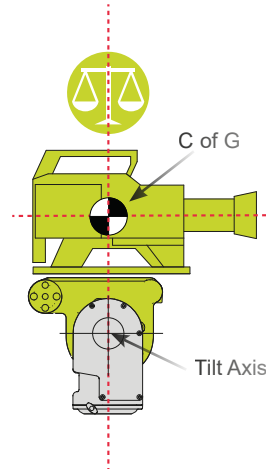

- When the C of G of the camera is approximately over the tilt axis, adjust the counterbalance as follows. Hold the payload and release the tilt lock, then gently tilt the load from the horizontal position fore 30 - 45° and release slowly then aft 30 - 45° and release again, observing its response.

- If the camera springs back toward horizontal then the counter balance requires lowering, turn the counterbalance counterclockwise.
  - If the camera drops away from the horizontal then the counterbalance needs to be higher, turn the counterbalance clockwise
- When the camera stays in whatever position it is placed in through the tilt range then counterbalance is correct.



After adjusting the counterbalance, you may notice slightly different behaviour when tilting fore as opposed to aft, i.e. tilting fore may try to fall away from horizontal but tilting aft is fine. This means that step 4 was not aligned perfectly. Repeat the process from step 4 to 6 until the camera will stop in any selected angle. This may require several repeat attempts to achieve perfect balance.



**Tip.** Turn the counterbalance anticlockwise for smaller payloads.  
Turn the counter balance clockwise for larger payloads.

After balancing, exercise the head through both axis to confirm that it operates smoothly.

# Operation

## Operating the Pan and Tilt Locks

The pan and tilt friction locks are operated by the levers on the left side of the head.

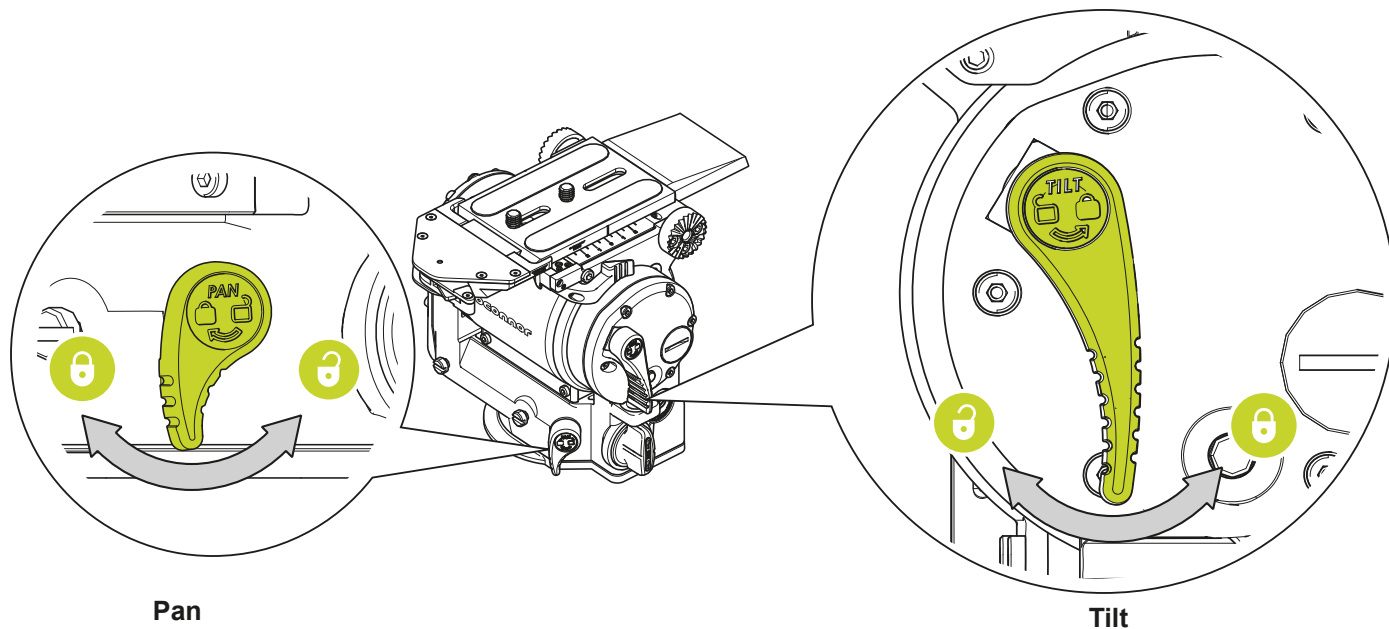

After prolonged use, if the lock does not fully engage at the end of the lock travel, refer to “Adjust Lock Levers” on page 20. The levers are designed so they can be released simultaneously with one hand.

## Pan and Tilt Fluid Drag

The pan drag adjustment knob is located on the lower right rear of the head, and the tilt drag adjustment knob on the lower left of the head. Both controls are continuously adjustable from 1 to 5. To increase drag, turn the knob clockwise, to decrease the drag, turn the knob counter-clockwise.

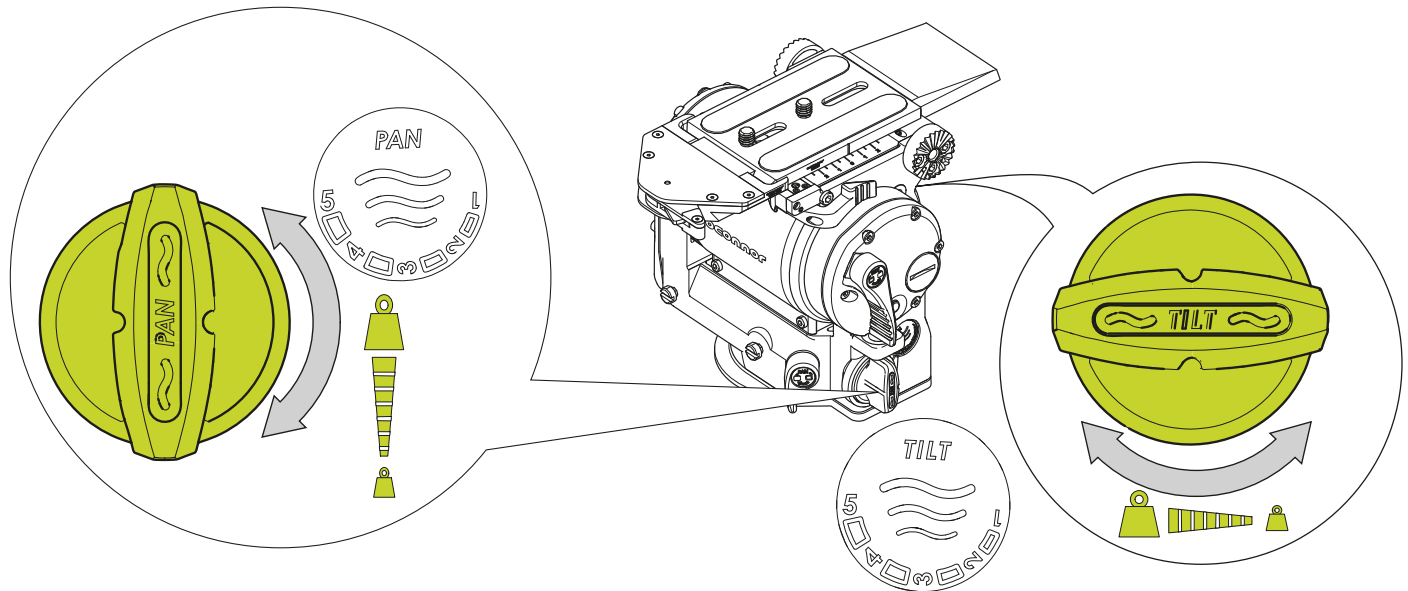

## Battery Replacement

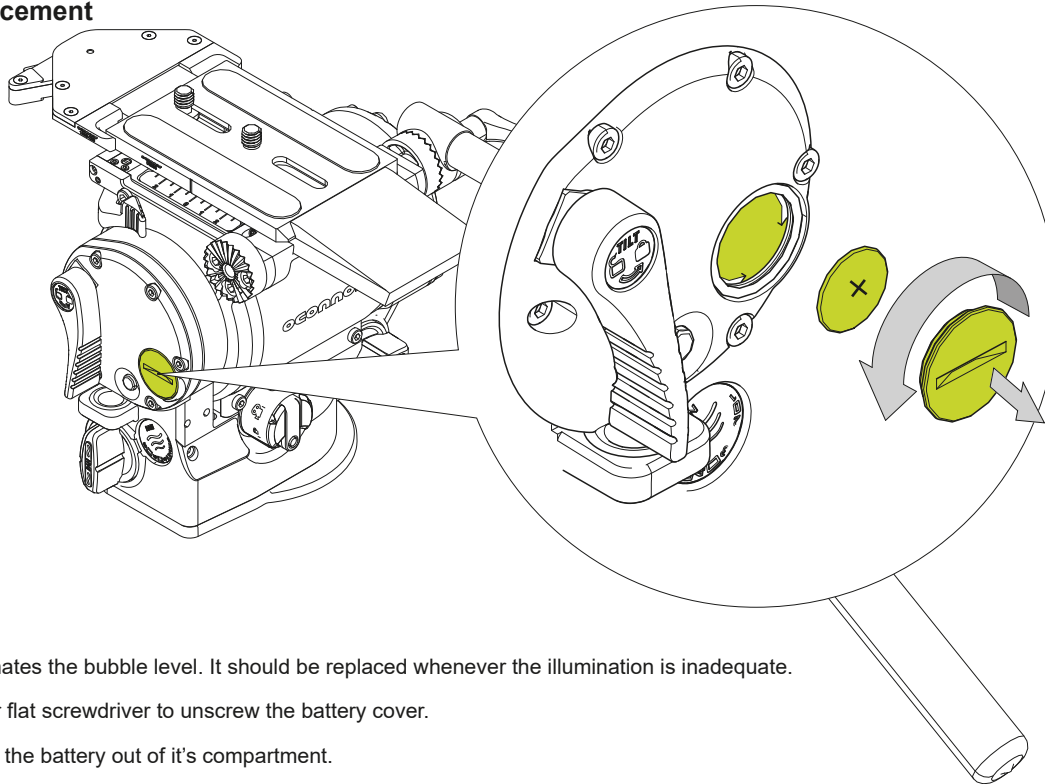

The battery illuminates the bubble level. It should be replaced whenever the illumination is inadequate.

1. Use a coin or flat screwdriver to unscrew the battery cover.
2. Carefully pull the battery out of it's compartment.
3. Fit a replacement CR 2032 3V battery in the compartment, ensuring that the positive side (+) of the battery faces outmost.
4. Replace the battery cover and tighten using a coin or flat blade screwdriver.
5. Press the bubble level illumination button and verify that the bubble is lit for approximately 20 seconds.

Ensure the old battery is disposed of responsibly, visit [www.http://www.ocon.com/support/weee-recycling/](http://www.ocon.com/support/weee-recycling/) for further information and advice.

## Adjust Lock Levers

If the pan and / or tilt friction locks do not fully engage at the end of the lock lever travel, adjust the lever position as follows:

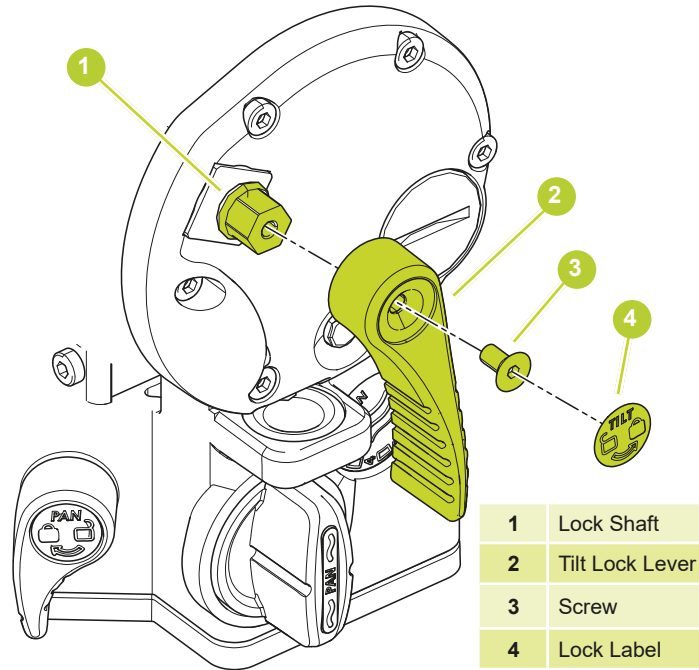

1. Rotate the lock lever to the locked position.
2. The lock lever is attached by means of a screw. Carefully peel away the lock label to expose the screw. Using Hex key, remove the screw

3. Pull the lever off the hexagonal shaft, rotate it approximately 30° away from the “locked” end of the travel, and reinstall it.
4. Tighten the screw. Reapply the lock label.

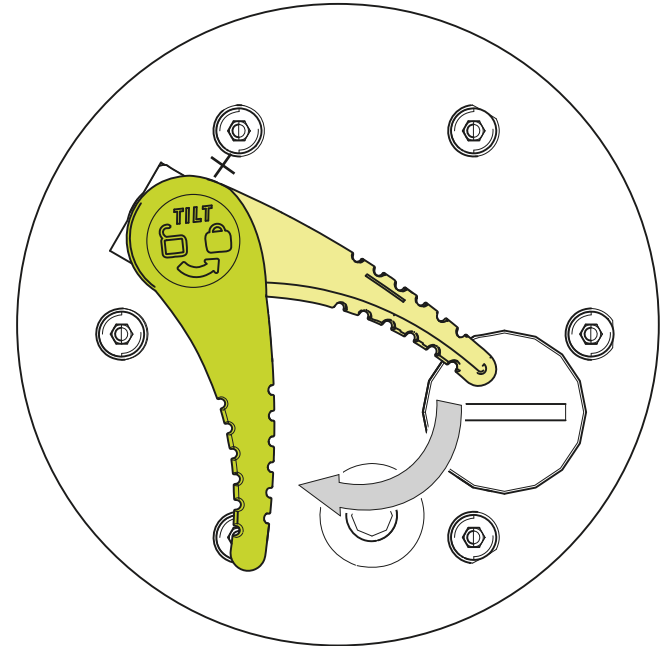

# Maintenance

## Adjust Camera Plate

1

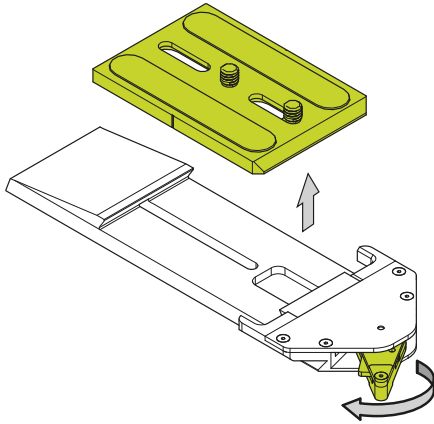

If movement is detected in the camera plate or the lock lever is too stiff, the clamp must be adjusted. Release the clamp lever (turn clockwise) and lift out the camera plate.

2

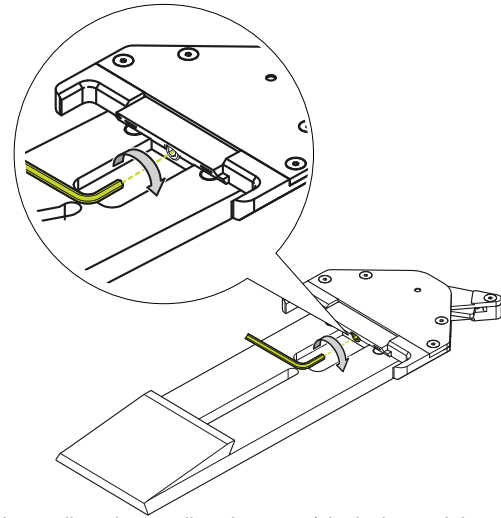

Using a hex key, adjust the small grub screw (clockwise to tighten the clamp and counterclockwise to loosen the clamp). Make small adjustments of between  $\frac{1}{8}$  and  $\frac{1}{4}$  turns.

3

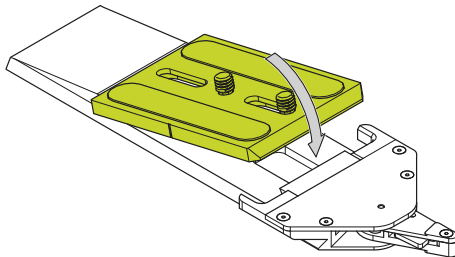

Replace the camera plate, the lever will snap in to the secure position.

4

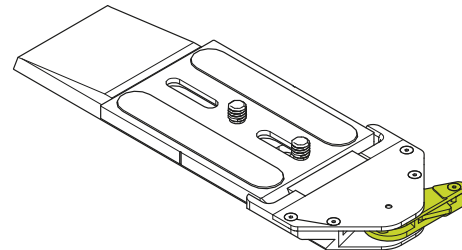

Push the clamp lever fully counterclockwise to lock the plate. Check the plate for movement and adjust again if necessary. The clamp lever should be operable with the pressure of just one finger.



## Height

8 in. (20.3 cm)



## Depth

7.5 in (19.1 cm)



## \*Maximum payload

45 lb (20 kg)



## Storage temp.

-40°F to +140°F  
(-40°C to +60°C)



## Bubble level

Illuminated



## Width

11.3" (28.7 cm)



## Weight

16.2 lb (4.8 kg) with large Euro plate + Tie down



## Weight

0.88 lb (0.4 kg) Pan Bar



## Tilt

±90° throughout entire counterbalance range, zero to max.



## Operating Temp.

-40°F to +140°F  
(-40°C to +60°C )



## Battery

Type: 1 x CR 2032 3v

\*Capacity:

@ 4" (100mm) <52 lb. (23.5 kg)

@ 5" (127mm) <45 lb. (20.4 kg)

@ 6" (152mm) <40 lb. (18.1 kg)

@ 8" (203mm) <33 lb. (14.9 kg)

**oconnor**



**OConnor**  
A Videndum plc Brand

[www.ocon.com](http://www.ocon.com)